

Pressure sensor M01

Sensors

KEY FEATURES

- Compact and robust design for use in harsh environments
- Pressure transmitter for mobile hydraulics, alternative drives (H2, CNG, LPG) and industrial sectors
- Maximum flexibility through modular design, customization and individualization possible
- Designed for OEM needs
- With ECE type approval
- UL Recognized

*1 Pressure range on request

TECHNICAL DATA

- Pressure ranges from 0...0,25 bar to 0...10 bar (relative and absolute)*1
- Pressure ranges from 0...10 bar to 0...2000 bar (relative)
- Overload pressure at least 2X nominal pressure
- Media temperatures up to 150 °C / 302 °F
- Ingress Protection Rating up to IP6K9K
- CAN enabled: CANopen, J1939, STW proprietary
- All common analog output signals available

ACCESSORIES

- Optional software package for CAN interface setting parameters

Sensor-Technik Wiedemann GmbH

Am Bärenwald 6
87600 Kaufbeuren

+49 8341 9505-0
info@sensor-technik.de
www.stw-mm.com

TECHNICAL DATA

Pressure range	0 ... 0.25 bar to 0 ... 2000 bar, other ranges available														
Pressure reference	relative R (gauge G) / absolute A*¹							relative R (gauge G)							
Standard pressure range	0.25 bar	0.4 bar	1 bar	1.6 bar	4 bar	10 bar	10 bar	25 bar	50 bar	100 bar	250 bar	400 bar	800 bar	1200 bar	2000 bar* ²
Overload pressure (per DIN EN 60770-1)	0.63 bar	1 bar	2.5 bar	2.5 bar	10 bar	20 bar	40 bar	40 bar	100 bar	200 bar	500 bar	800 bar	1000 bar	1600 bar	2200 bar
Bursting pressure (per DIN EN 60770-1)	0.75 bar	1.2 bar	3 bar	3 bar	12 bar	30 bar	70 bar	70 bar	500 bar	1000 bar	2500 bar	4000 bar	> 4000 bar	> 4000 bar	> 4000 bar
Media temperature	-40 ... +85 °C / -40 ... +185 °F							-40 ... +150 °C / -40 ... +302 °F							
Operating and storage temperature	-40 ... +85 °C / -40 ... +185 °F							-40 ... +125 °C (-25 ... +85 °C at cable output) -40 ... +257 °F (-13 ... +185 °F at cable output)							
Material with medium contact	Stainless Steel AISI 630 (DIN 1.4542) and Silicon (For applications with non-aggressive gases and fluids or substances which do not react with glass or silicon)							Stainless Steel AISI 630 (DIN 1.4542), AISI 316 L (DIN 1.4435) on request							
Overall accuracy at operating temperature	≤ 1.0 %FS (0 ... +85 °C) / (32 ... +185 °F) ≤ 2.5 %FS (-40 ... 0 °C) / (-40 ... +32 °F)							≤ 0.5 %FS (0 ... +105 °C) / (32 ... +221 °F) ≤ 1.5 %FS (-40 ... 0 °C and +105 ... +125 °C) / (-40 ... +32 °F and +221 ... +257 °F)							
Thereof linearity, pressure hysteresis and repeatability (Linearization with limit point setting)	< 0.25 %FS														
Material wetted parts and housing	Stainless steel, AISI 304 (DIN 1.4301)														
Material connector	glass-fiber reinforced plastic (PBT) or AISI 304 (DIN 1.4301)														
Installation torque	max. 35 Nm														
Long-term stability	< 0.2 %FS p.a.														
Voltage supply (DC)	U_{VCC} : 9 ... 36 V U_{VCC} : 14 ... 36 V (for transmitter with 0 ... 10 V voltage output) U_{VCC} : 5 V ± 10 % (for transmitter with ratiometric output)														
	allowable ripple at 50 Hz: 10 %														

*1 Pressure range on request

*2 For common-rail applications

TECHNICAL DATA

CAN	Sampling Rate	1000 Samples/s (max.)
	Digital Filter	averaging adjustable
	Output protocol	STW-CAN, CANopen, SAE J1939
	Electrical connection	M12 connector, DIN Bayonet (per DIN 72585), DT04 4-pole, cable output
Analog	Output signal	4 ... 20 mA (2-wire technique), 0/4 ... 20 mA (3-wire technique), 0 ... 10 V, 0 ... 5 V, 1 ... 6 V, 10 ... 90 % VCC (ratiometric output) Other output signals on request
	Electrical connection	M12 connector, DIN bayonet (per DIN 72585); DT04 4-pole; DT04 3-pole, AMP-SuperSeal 1.5; cable output Other connectors on request
Electrical protection	Short circuit protected, signal on GND/VCC and inverse polarity protection (not at ratiometric output)	
Pressure connection	G 1/4, 1/4 NPT, G 1/4 with manometer pin, SAE04 (7/16-20UNF), SAE06 (9/16-18UNF), other pressure connectors on request, possible limitations of the pressure range	
Protection class	IP6K7 or IP6K9K (depends on the electrical connection)	

Functional safety

Pressure switch M01 (analog and CAN)	Acc. DIN EN ISO 13849-1: Performance Level b
	Cat. = B
	MTTF _d = High
	DC = None
	CCF = Not relevant

TECHNICAL DRAWINGS AND PIN ASSIGNMENTS

Pressure connection

G 1/4,
DIN 3852 T 11
(Form E)

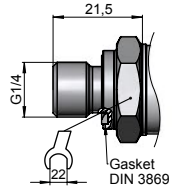

1/4 NPT per
„Nominal width
for US-standard
bevelled pipe
thread NPT“

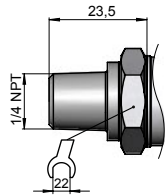

G 1/4 according
to EN837-1
(formerly
DIN 16288)

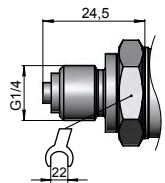

SAE04 - O-Ring

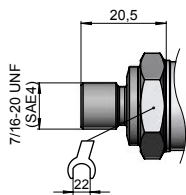

Electrical connection, protection class IP per IEC 60529

Circular plug-in connector
M12x1, 5-pole, IP6K7

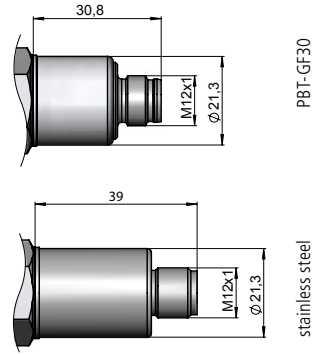

CAN + Analog

Bayonet connector
DIN 72585, 4-pole, IP6K7

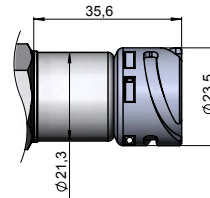

Connector
DT04-4P, 4-pole, IP6K7

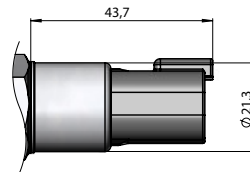

Cable output IP69k
(Oil-resistant cable on
request)

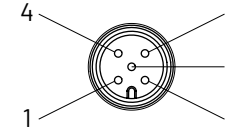
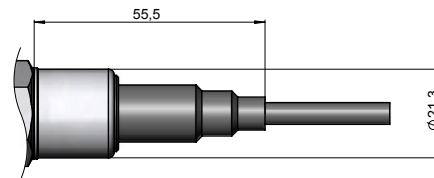

Pin	2-wire technique	3-wire technique	CAN
1	VCC	VCC	PE, housing
2	-	-	VCC
3	SIG	GND	GND
4	-	SIG	CAN_H
5	-	-	CAN_L

Do not connect the pins marked with „-“!

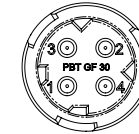

Pin	2-wire technique	3-wire technique	CAN
1	VCC	VCC	VCC
2	SIG	GND	GND
3	-	SIG	CAN_H
4	-	-	CAN_L

Do not connect the pins marked with „-“!

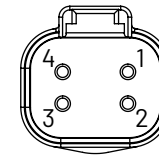

Pin	2-wire technique	3-wire technique	CAN
1	VCC	VCC	CAN_L
2	SIG	GND	VCC
3	-	SIG	GND
4	-	-	CAN_H

Do not connect the pins marked with „-“!

Litz wire	2-wire technique	3-wire technique	CAN
brown	VCC	VCC	PE, housing
white	-	-	VCC
blue	SIG	GND	GND
black	-	SIG	CAN_H
grey	-	-	CAN_L

Do not connect the litz wires marked with „-“!

TECHNICAL DRAWINGS AND PIN ASSIGNMENTS

Pressure connection

SAE04
Cone

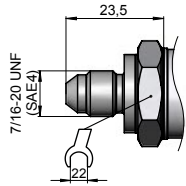

SAE06
O-Ring

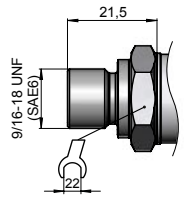

Electrical connection, protection class IP per IEC 60529

Analog

Connector for
AMP-SuperSeal 1,5
3-pole, IP6K7

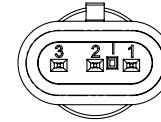
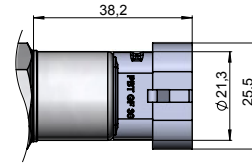

Connector DT04-3P
3-pole, IP6K7

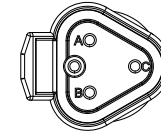
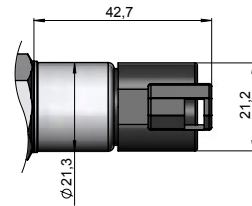

Pin	2-wire technique	3-wire technique
1	SIG	GND
2	-	SIG
3	VCC	VCC

Do not connect the pins marked with „-“!

Pin	2-wire technique	3-wire technique
A	VCC	VCC
B	-	SIG
C	SIG	GND

Do not connect the pins marked with „-“!

Recommended terminal layout

2-wire technique

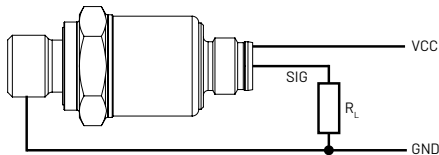

3-wire technique

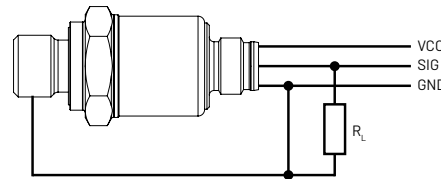

CAN

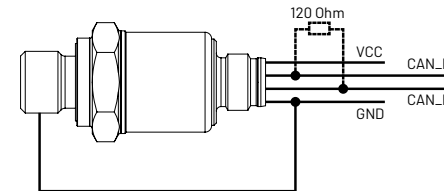

Current output load $R_L \leq \frac{U_{VCC} - 9V}{0,02A}$ for $U_{VCC} \geq 24V$ additionally $R_L \geq \frac{U_{VCC} - 24V}{0,048A}$

Voltage output load: $R_L \geq 10k\Omega$

QUALIFICATION

Conformity

CE, UL
 E1: All vehicle types with a 12 V resp. 24 V - electrical wiring and battery (-) at the body

DETAILED QUALIFICATIONS

EMC industrial (CE)

RF Emission 150 kHz to 30 MHz conducted, 30 MHz to 1GHz, group 1 class B	EN 61000-6-3 residential, commercial and light-industrial environments
Electromagnetic immunity	EN 61000-6-2 industrial environments
ESD: 330 Ω / 150 pF; contact: +/-4 kV, air: +/-8 kV	EN 61000-4-2
RF immunity: 80-2700 MHz, 10 V/m, 3 m, hor./vert.	EN 61000-4-3
Burst: 5/50 ns, 5 kHz; signal wire.: +/-1 kV, power supply wire: +/-2 kV	EN 61000-4-4
Surge: 1,2/50 μ s; symm., asymm.: +/-0,5 kV	EN 61000-4-5
Conducted. RF immunity: 0,15-80 MHz, 10 V, 80 % AM sine 1 kHz	EN 61000-4-6

FCC, 47 CFR Part15, Subpart B

Equivalent to FCC Docket 92-152	Confirmation
---------------------------------	--------------

EMC automotive

RF emission 150 kHz to 3 GHz, 1m, 120 kHz bandwidth	DIN EN 55025:2003-11, IEC/CISPR 25:2002
RF immunity: stripline: 0,01 MHz-400 MHz, 200 V/m, 80 % AM sine with 1 kHz; antenna: 400 MHz - 2 GHz, 50 V/m, PM tON, 577 μ s, period 4600 μ s	ISO 11452-5:2002-04, ISO 11452-2:2000-03
Road vehicles, electrical disturbances, test pulse (power supply wires): Pulse 1: -600 V, 5000 pulses	ISO 7637-2:2004-09
<ul style="list-style-type: none"> • Pulse 2a: +50 V, 5000 pulses, 2 Ω • Pulse 2b: +20 V, 10 pulses • Pulse 3a: -200 V, 1 h • Pulse 3b: +200 V, 1 h • Pulse 4: -16 V, 2 pulses • Pulse 5: 62 V, 400 ms, 2 Ω, 1 pulse 	

QUALIFICATION

EMC automotive

Road vehicles, electrical disturbances, test pulses (data wires):	ISO 7637-3:1995-07
<ul style="list-style-type: none"> Pulse a: -80 V, 1h Pulse b: +80 V, 1h 	
Radio disturbance for protection of receivers used on board vehicles, boats und large devices; 0,15 MHz-108 MHz	IEC/CISPR 25:2002, DIN EN 55025:2003-11
Electrostatic discharge; 2 kΩ / 330 pF, 2 kΩ / 150 pF; kontakt: +/-8 kV, air:+/-15 kV	ISO 10605:2001-12
Packaging and handling (contact: +/-8 kV)	ISO 10605:2001-12

Climatic and mechanical tests

Temperature range	-40 °C ... +125 °C / -40 °F ... +257 °F
Thermal-cycling test na: -40 °C / -40 °F and 125 °C / 257 °F; 10 cyc.; retaining of limit temperature for 1h; temperature change rate 30 sec., active	DIN EN 60068-2-14:2000-08
Thermal-cycling test na: -50 °C / -58 °F and 125 °C / 257 °F; 216 cyc.; retaining of limit temperature for 0,5h; temperature change rate 30 sec., passiv	DIN EN 60068-2-14:2000-08
Thermal-cycling test nb: -40 °C / -40 °F und 125 °C / 257 °F; 10 cyc.; retaining of limit temperature for 1h; temperature change rate 3K/min., active	DIN EN 60068-2-14:2000-08
Cold test -40 °C / -40 °F, duration: 96 h, active	DIN EN 60068-2-1:1995-03
Dry heat +125 °C / 257 °F, duration: 96 h, active	DIN EN 60068-2-2 :1994-08 DIN EN 60068-2-2/A2 :1995-01
Damp heat, steady state: 21 days at 40 °C / 104 °F and 96 % r.F.	DIN EN 60068-2-78:2002-09
Damp heat cyclic 25 °C / 77 °F to 55 °C / 131 °F; at 96 % r.F.; 6 cycles each 24 h, active	DIN EN 60068-2-30:2000-02, DIN 50016:1962-12

Climatic and mechanical tests

Free fall: 1 m free fall on iron plate, 6 axes	DIN EN 60068-2-32:1995-03
Degree of protection (water/dust) IP6K7 and IP69K; depending on connector type	DIN EN 60529:2000-09, DIN 40050-9:1993-05
Vibration (sinusoidal) 20 g, test with temperature variation, 5-2000-5 Hz, 1 oct/min., -40 °C...125 °C / -40 °F...257 °F, 3 K/min, tv=15 min, tw=60 min, 2 temp. cycles/axis (->3x5 h)	DIN EN 60068-2-6 DIN EN 60068-2-14Nb
Shock: 50 g / 11 ms; sine; 3 shocks per axis; not active	DIN EN 60068-2-27:1995-03
Shock 500 g, 1-2 ms, 18 shocks, 6/axis	DIN EN 60068-2-27:1995-03
Bump: 30 g / 6 ms, sine, 1000 bumps per axis	DIN EN 60068-2-29:1995-03
Salt mist, cyclic (sodium chloride solution): 5 % NaCl, 4 cycles a 24 h, 35 °C / 95 °F, 2 h/22 h	DIN EN 60068-2-52:2000-02
Immersion and splash: gasoline, diesel, degreaser, antifreezing agent, afterwards drying at 125 °C / 257 °F for 48 h	SAE J 1211 part 4.4:1978-11
Chemical resistance: diesel, motor oil, hydraulic oil, gear oil, bio-diesel, E10, urea "Caelo" afterwards drying at 70 °C / 158 °F for 48 h	ISO 16750-5
Ice-water shock test	ISO16750-4
Flowing mixed gas corrosion test: sulfur dioxide SO2, hydrogen sulfide H2S, nitrogen dioxide NO2, chlorine Cl2	DIN EN 60068-2-60 (16750-4)

ORDER CODES

Model
|
M01

----- *Select other parameters (one per category)*

Units		Reference		Output			Pressure Connection		Electrical Connection	
<input type="checkbox"/>	bar	<input type="checkbox"/>	Gauge	<input type="checkbox"/>	4-20 mA (2-wire-technique)	<input type="checkbox"/>	G 1/4"	<input type="checkbox"/>	M12 (Plastic)	
<input type="checkbox"/>	PSI	<input type="checkbox"/>	Absolute (≤ 10 bar)	<input type="checkbox"/>	0-20 mA (3-wire-technique)	<input type="checkbox"/>	1/4" NPT	<input type="checkbox"/>	DT04 (4-Pole)	
				<input type="checkbox"/>	4-20 mA (3-wire-technique)	<input type="checkbox"/>	G 1/4" with manometer	<input type="checkbox"/>	DT04 (3-Pole)	
				<input type="checkbox"/>	0...10 V	<input type="checkbox"/>	SAE 04 (7/16-20 UNF with cone)	<input type="checkbox"/>	M12 (Steel)	
				<input type="checkbox"/>	0...5 V	<input type="checkbox"/>	SAE 04 (7/16-20 UNF with o-ring)	<input type="checkbox"/>	Custom (Specific)	
				<input type="checkbox"/>	1...6 V	<input type="checkbox"/>	SAE 06 (9/16-18 UNF with o-ring)			
				<input type="checkbox"/>	10...90% VCC	<input type="checkbox"/>	Custom (Specific)			
				<input type="checkbox"/>	CANopen					
				<input type="checkbox"/>	SAE J1939					
				<input type="checkbox"/>	STW-CAN					
				<input type="checkbox"/>	Custom (Specific)					